

Slurry Tanker

ST1300

Constructed from 6mm plate.
Internal protective coating for extended life.
6" filler and discharge points.
Five stage paint process to ensure maximum protection and durability.

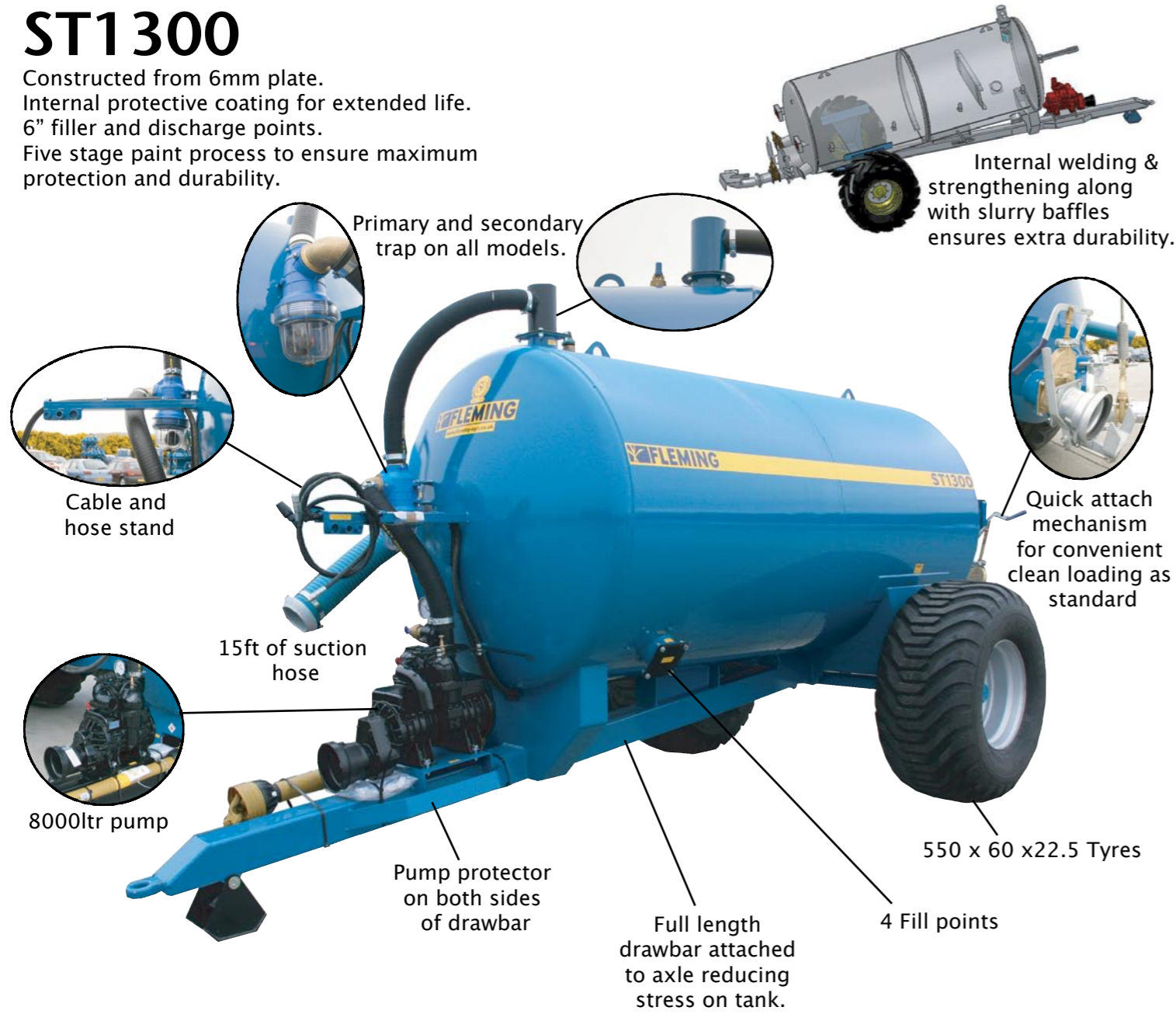

FLEMING AGRI-PRODUCTS LTD Newbuildings Industrial Estate, Newbuildings, Northern Ireland BT47 2SX
Tel: +44 (0)28 7134 2637 Fax: +44 (0)28 7134 4735 Email: info@fleming-agri.co.uk www.fleming-agri.co.uk

Slurry Tanker



ST1300 ST1600
ST1600N ST2000

Code	ST1300	ST1600N	ST1600	ST2000
Pump (Lpm)	8000	8000	8000	11000
Transport Width	2560mm	2560mm	2500mm	2500mm
Length	5400mm	6100mm	6100mm	7000mm
Unladen Weight	2100kgs	2280kgs	3340kgs	3500kgs
Tyres	550/60-22.5	550/60-22.5	28.1 R26/10	28.1 R26/10
Tyre Options	21.3xR24	21.3 R24	N/A	30.5 R32
Wall Thickness	6mm	6mm	6mm	6mm

Due to a policy of continual improvement the company reserve the right to change price or specification without notice

ST2000

Internal protective coating for extended life.
Five stage paint process to ensure maximum protection and durability.
6" filler and discharge points.
Galvanised rear inspection hatch.

Internally welded, baffled and braced for extra durability

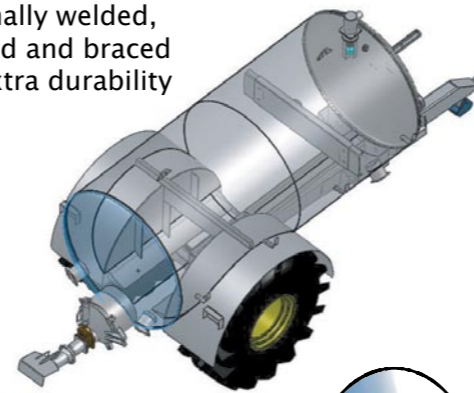

Quick attach mechanism for convenient clean hose attachment



Primary and secondary trap on all models

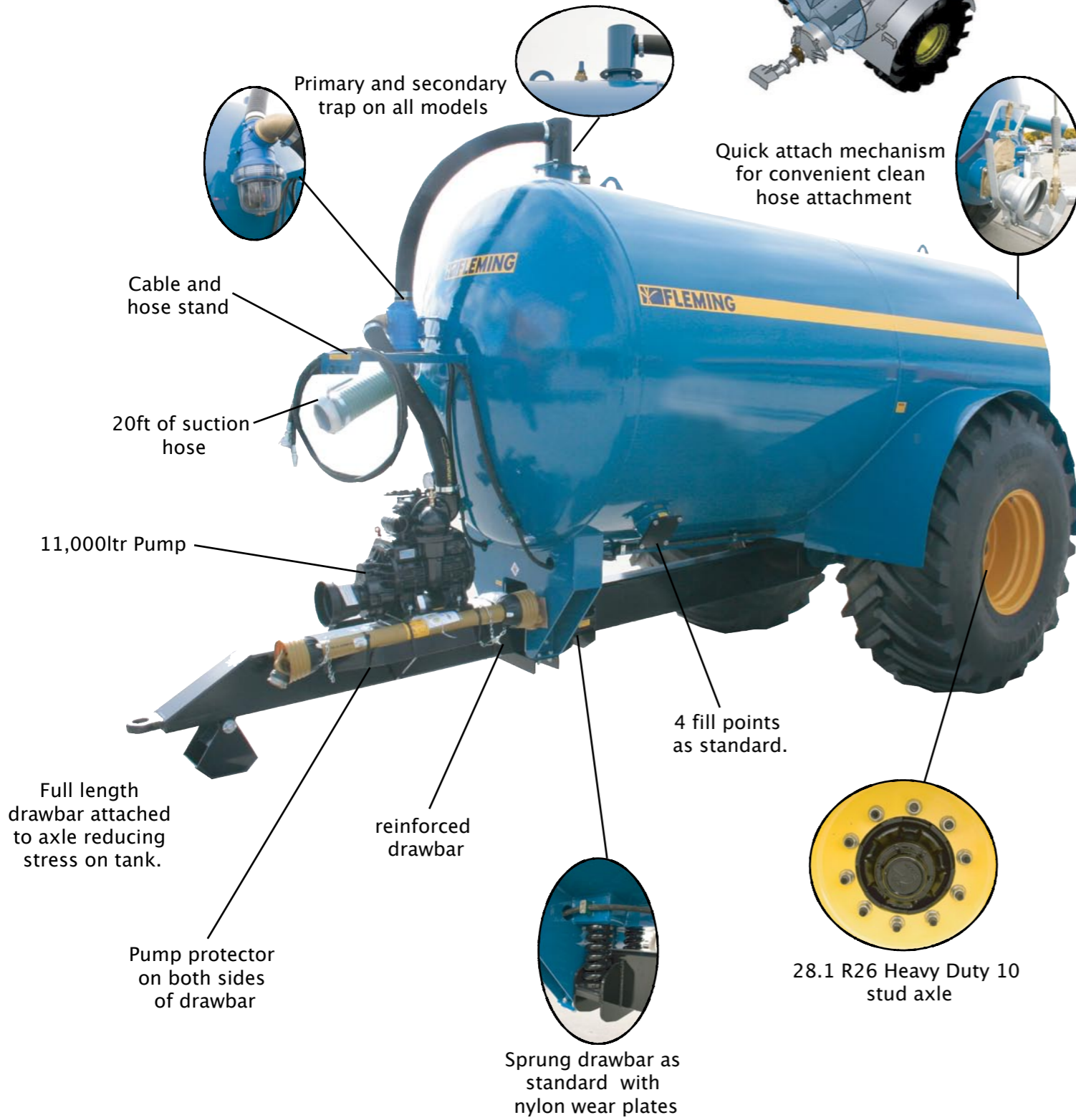

ST1600

Constructed from 6mm plate.
Internal protective coating for extended life.
Five stage paint process to ensure maximum protection and durability.
Full length drawbar attached to axle reducing stress on tank.
Galvanised rear inspection hatch.
4 Fill points.



8000ltr pump

reinforced drawbar

Sprung drawbar as standard with nylon wear plates

28.1 R26 Heavy Duty 10 stud axle



ST1600N

Constructed from 6mm plate.
Internal protective coating for extended life.
Five stage paint process to ensure maximum protection and durability.
20ft of suction hose on tanker.
Galvanised rear inspection hatch.

